

# Sampling Flammable Gas Detector

## GTD-5000Ex

### Feature

- ▷ Fast response of flammable gases leakage with a high efficient pump inside
- ▷ Self diagnosis function with built-in Microprocessor
- ▷ Easy replacement with a cartridge type sensor
- ▷ Digital flow sensor to maintain regular flow rate
- ▷ Detection gas from low to high concentration owing to various detection principle
- ▷ Stable quality and proved detection principle for service life
- ▷ Fine LCD display for showing various information
- ▷ 4-digit digital gas concentration display
- ▷ 4-20mA DC output signal
- ▷ Easy configuration of monitoring by RS-485 Modbus isolated serial data communication or PoE(Optional)
- ▷ 2-stage alarm, 1-trouble display and relay contact output
- ▷ 3-wire connection for signal & power
- ▷ Calibration and maintenance by one-man



## General

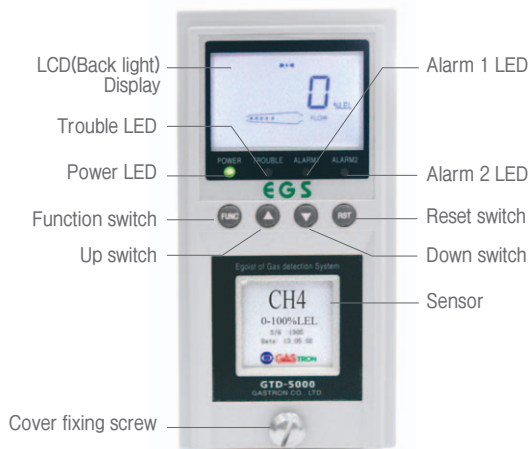

## Dimension (Unit:mm)

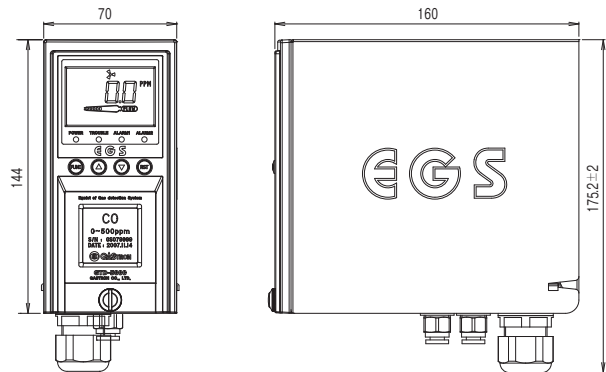

## Accessories

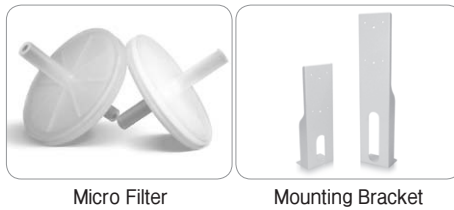

## Specification

※ Specifications are subject to be changed without prior notice.

SAMPLING FLAMMABLE GAS DETECTOR	
Model	GTD-5000Ex
Measuring gas	Flammable gases (LNG, LPG, H <sub>2</sub> , Methane, Butane & etc)
Measuring type	Auto Sampling type
Measuring method	Catalytic cell      Hot wire semiconductor cell      Thermal conductivity cell
Measuring range	0~100% LEL      0~2000ppm      0~100% Vol
Response time	<15 sec / 90% scale
Accuracy	± 3% / Full scale
Parameter control	Front switch (calibration, maintenance, alarm setting)
Operation mode display	4-LED (Power, 2-stage alarm, 1-trouble)
Measuring value display	LCD Display(4-Digit)
Alarm signal output	250V 1A / 3-SPST relay contact (2-stage alarm, 1-trouble)
Output signal	4 - 20mA DC RS-485 Modbus(Optional) / PoE(Power over Ethernet)(Option)
Sampling method	Diaphragm Pump
Sampling line	OD 1/4" (Standard)
Flow rate	0 ~ 1000 ml/min max
Cable/Distance	Power + Signal cable : 3-wire > 1.5sq(AWG16) / 2500m max RS-485 data communication cable : 1 pair(UL2919 RS-485) / 1000m max PoE(Power over Ethernet) : 100m max
Conduit connection	Cable gland(PG-16)
Mounting type	Wall mount
Operating temperature	-20℃ ~ +60℃
Operating humidity	5 to 99% RH (Non-condensing)
Operating power	Standard : 18 ~ 31V DC (24V DC normal) / 280mA max PoE(NOTE 1) : 48V DC ± 10% / 200mA max
Material	Front(Poly carbonate), Sides(Steel)
Dimensions	Standard type : 70(W) × 144(H) × 160(D) mm
Weight	Standard type : 2.5kg
Approval	CE ( EN50270:1999 )
NOTE 1	DC 24V should be supplied if you want to use Pyrolyzer in case of using PoE power